



PDU Power

“Complete Guide
for Power
Distribution in
Servers, Racks,
and Data
Centers”

AUTHOR

Richard Nicolaus

ORGANIZATION

Technology Movers

PUBLICATION DATE

July 22, 2025

TABLE OF CONTENTS

03

Introduction

04

Understanding PDUs (Power Distribution Units)

06

Why PDUs Matter in Data Centers

07

Power Inputs for PDUs

08

Types of Power Connectors for Input

09

PDU Output Connectors and Receptacles

11

How to Choose the Right PDU for Your Data Center

13

Safety and Efficiency Considerations

15

Conclusion

Introduction

Powering the Digital Backbone

Power distribution is the bedrock of every successful data center. Without reliable, efficient power delivery, even the most advanced servers and networking equipment are rendered useless. Modern data centers face escalating challenges as server densities grow and power requirements intensify, making robust power infrastructure planning paramount for both operational success and financial viability.

Power Distribution Units (PDUs) are the crucial link between your facility's electrical infrastructure and your IT equipment. These devices ensure clean, stable power reaches every server, switch, and storage device in your racks, while offering the monitoring and control capabilities vital for modern data center management. From basic distribution to advanced monitoring and remote switching, PDUs have evolved into sophisticated tools that empower data center operators to maximize uptime, optimize efficiency, and maintain precise control over their power infrastructure.

Inadequate power planning can lead to unexpected downtime, reduced equipment lifespan, fire hazards, and significant financial losses. Conversely, well-designed power distribution systems enable data centers to operate at peak efficiency and provide the scalability needed for future growth.



Understanding PDUs

A Power Distribution Unit (PDU) is a specialized electrical device designed to distribute power from a single input source to multiple output receptacles, specifically engineered for data center and IT environments. Unlike standard power strips, PDUs are built to handle the demanding requirements of enterprise equipment, featuring robust construction, precise power management, and often sophisticated monitoring capabilities.

PDUs serve multiple functions beyond simple power distribution. They provide a centralized point for power management; enable load balancing across circuits, offer protection against power anomalies and in advanced models, deliver real-time monitoring and remote control capabilities. This makes them indispensable components in any professional IT environment.

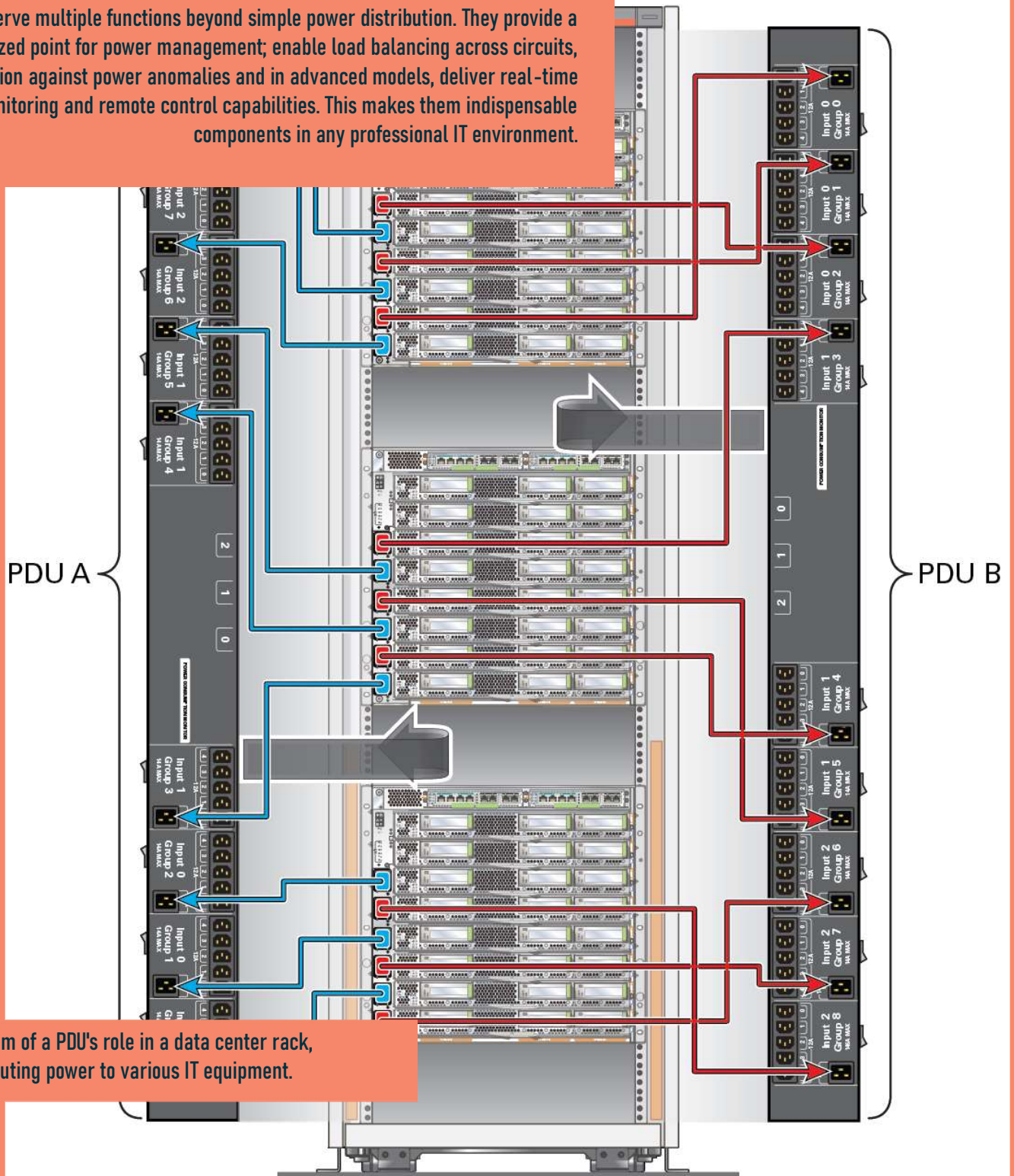

Diagram of a PDU's role in a data center rack, distributing power to various IT equipment.

The three primary categories of PDUs each serve different operational needs:



Basic PDUs

Provide foundational, reliable power delivery without monitoring capabilities. They focus on robust construction and dependable performance, ideal for environments where simple, cost-effective power distribution is the primary requirement.

Monitored PDUs

Add intelligence by providing real-time visibility into power consumption, environmental conditions, and system status. These units enable proactive power management and capacity planning while maintaining the reliability of basic models.



Switched PDUs

Offer the highest level of control, combining monitoring capabilities with remote power switching for individual outlets. This enables remote equipment reboot, scheduled power cycling, and precise power management at the device level.



Why PDUs Matter in Data Centers

The importance of properly selected and configured PDUs spans multiple critical areas of data center operation:

Efficiency

Modern PDUs help minimize power loss through intelligent load balancing and high-efficiency components. Many advanced PDUs achieve 95% or higher efficiency ratings, directly impacting operational costs and environmental footprint.

Safety

Quality PDUs incorporate overcurrent protection, surge suppression, and proper grounding to protect both equipment and personnel. They also enable safe maintenance procedures through controlled shutdown capabilities and clear circuit identification.

Load Mgmt.

By providing detailed power consumption data and enabling dynamic load balancing, PDUs help prevent circuit overloads while maximizing the utilization of available power capacity. This capability is increasingly important as server power densities continue to climb.

Power Inputs for PDUs

Single-Phase vs. Three-Phase Power

Understanding the fundamental differences between single-phase and three-phase power systems is crucial for selecting appropriate PDUs and planning data center power infrastructure.

Single-Phase Power

Power systems utilize two conductors (hot and neutral) plus a ground conductor to deliver alternating current. In North American installations, single-phase power typically operates at 120V or 240V. These systems excel in smaller installations where simplicity and cost-effectiveness take priority over maximum power capacity.

- **Advantages:** Lower installation costs, simpler electrical infrastructure, easier troubleshooting and maintenance.
- **Common Applications:** Small business server rooms (5-10 rack units), network closets, edge computing installations, development/testing environments (typically requiring 20-30 amps).



Three-Phase Power

Three-Phase Power systems utilize three conductors carrying alternating current with phases offset by 120 degrees, plus a neutral and ground conductor. This configuration offers significant advantages for larger installations, particularly in terms of power capacity and efficiency.

- **Advantages:** More consistent power with reduced voltage fluctuations (ideal for sensitive IT equipment), higher power capacity within the same conductor size, improved efficiency for motor loads and high-capacity power supplies, better load balancing.
- **Common Applications:** Enterprise data centers with high-density server racks, colocation facilities, cloud computing installations, and any environment requiring more than 30-40 amps of total power capacity (practically necessary when individual racks exceed 10-15 kW).

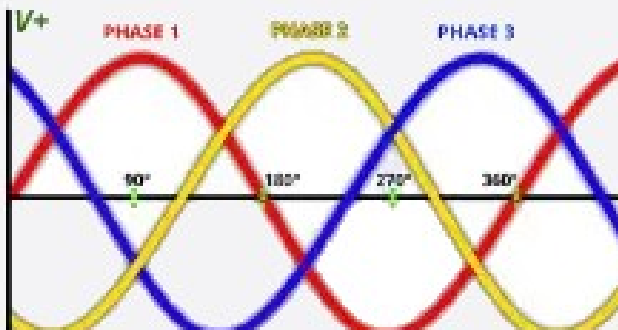

Types of Power Connectors for Input

Selecting appropriate input connectors ensures a safe, reliable connection between PDUs and facility electrical infrastructure. Each connector type is rated for specific amperage and voltage combinations, making proper selection critical for both safety and performance.

L15-20P (NEMA) Connectors

- **Rating:** 20-ampere, three-wire grounding applications at 250V single-phase or 208V three-phase.
- **Features:** Distinctive configuration with the grounding pin positioned to prevent insertion into incompatible receptacles.
- **Use:** Commonly used in medium-capacity server room



L30P Connectors

- **Rating:** Support 30-ampere applications in various voltage configurations.
- **Features:** L6-30P (250V single-phase), L21-30P (208V three-phase wye configurations).
- **Use:** Essential for high-capacity PDUs serving power-hungry equipment or multiple racks.



Other Important Connector Types

- **NEMA 6-15P:** 15-amp, 250V single-phase (smaller installations).
- **IEC 60309 (CEE form) connectors:** International standard, color-coded by voltage and keyed by amperage rating.

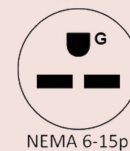

Required Receptacle Types

Selecting appropriate input connectors ensures a safe, reliable connection between PDUs and facility electrical infrastructure. Each connector type is rated for specific amperage and voltage combinations, making proper selection critical for both safety and performance

L15-20P connectors require L15-20R receptacles.

L30P connectors require matching L30R receptacles (e.g., L6-30R, L21-30R).

Installation Requirements: Proper conductor sizing, overcurrent protection, and grounding in accordance with local electrical codes. Professional electrical installation is essential for safety, code compliance, and optimal performance.

PDU Output Connectors and Receptacles

Common Output Types

PDU output configurations must match the power input requirements of connected equipment while providing appropriate capacity and protection. Modern IT equipment utilizes several standard connector types, each designed for specific power level

C14 Outlets



Use: Most common output type in data center PDUs, designed to accept C13 power cords used by most servers, switches, and storage devices.

Rating: Handle up to 15 amps at standard voltages.

Features: Provides reliable connection with positive retention, preventing accidental disconnection.

C20 Outlets



Use: Serve higher-power equipment requiring up to 20 amps of current capacity, accepting C19 power cords (high-end servers, large network switches, storage arrays).

Features: Larger conductor size and contact area handle higher currents safely while maintaining reliable connection integrity.

NEMA 5-15R Outlets:



Use: Provide standard North American 15-amp, 120V service for general-purpose equipment (office equipment, monitors, lower-power IT devices).

NEMA 5-20R Outlets:



Use: Deliver 20-amp capacity at 120V for more demanding loads, maintaining compatibility with standard 5-15P plugs through their T-slot configuration.

Features: Versatile for mixed equipment environments.

Matching Output to Equipment Needs

Proper output selection requires careful analysis of connected equipment power requirements, growth plans, and operational procedures. Understanding equipment power consumption patterns helps ensure adequate capacity while avoiding over-specification that increases costs unnecessarily.

Server Power Requirements: Vary significantly (processor type, memory, storage, utilization). Typical 1U servers consume 200-400 watts; high-end servers 800-1200+ watts; blade servers and high-density computing platforms can exceed these.

Networking Equipment: Depends on port count, switching capacity, and features like Power over Ethernet (PoE). Basic switches: 50-150 watts; large core switches: 1000+ watts.

Storage Systems: Vary widely from small NAS units (100-200 watts) to enterprise arrays (several kilowatts).

Planning Considerations:

Include **peak power consumption** rather than average, as many devices experience significant power variation during boot-up, high utilization, or thermal events.

Plan for **future equipment upgrades and capacity expansion** when selecting outlet quantities and types.



How to Choose the Right PDU for Your Data Center

Considerations When Choosing a PDU

Selecting appropriate PDUs requires comprehensive analysis of current requirements, future growth plans, and operational procedures. The decision process should consider both technical specifications and practical implementation factors.

Power Requirements Analysis:

- Detailed inventory of connected equipment: startup, continuous operating, and peak demand scenarios.
- Consider seasonal variations, workload cycles, and impact of equipment aging.
- Document current requirements and projected growth over the PDU's expected service life.

Number of Outlets:

- Account for equipment density, redundancy, and maintenance.
- Plan for 20-30% spare capacity for additions, replacements, and temporary connections.
- Consider equipment with dual power supplies.

Monitoring Needs:

- Vary based on operational requirements, compliance, and management preferences.
- Basic: total power consumption, basic alarms.
- Advanced: per-outlet power measurement, environmental sensors, integration with DCIM systems.

Form Factor:

- Horizontal PDUs: Mount in standard rack units, good for traditional racks.
- Vertical PDUs: Mount to rack rails, maximize outlet density in high-density installations.

Surge Protection:

- Depends on facility electrical quality, equipment sensitivity, and risk tolerance.
- Integrated surge protection may be justified for valuable equipment or areas with frequent electrical disturbances.



PDU Comparison Chart	BASIC	Metered	Monitored	Switched
In Rack - Multiple Outlets	✓	✓	✓	✓
Reliable Power Distribution	✓	✓	✓	✓
Digital Load Meter Reports Power Consumption		✓	✓	✓
Network Interface Enables Remote Monitoring			✓	✓
Switched Outlets - Power Control Programmable or Real-Time				✓

Choosing Between Basic, Monitored, and Switched PDUs

The decision should align with operational requirements, budget constraints, and management capabilities.

Basic PDUs:

- **Benefits:** Reliable power distribution, lowest cost and complexity.
- **Ideal for:** Environments where power monitoring occurs at facility level, simplicity is prioritized, or budget constraints limit advanced features.
- **Applications:** Small business installations, branch offices, development environments, temporary deployments.

Monitored PDUs:

- **Benefits:** Valuable visibility into power consumption, environmental conditions, system status. Enables proactive capacity planning, efficiency optimization, trend analysis.
- **Ideal for:** Medium to large installations where power visibility is important, environments requiring capacity planning/optimization, installations with compliance/reporting requirements, facilities implementing DCIM.

Switched PDUs:

- **Benefits:** Highest level of control through individual outlet switching (remote reboot, scheduled power cycling, precise power control).
- **Ideal for:** Critical installations requiring remote management, environments with frequent equipment maintenance, installations supporting remote/lights-out operations, facilities requiring automated power cycling/scheduling.

Safety and Efficiency Considerations

How to Ensure Safe Power Distribution

Safety in power distribution extends beyond avoiding electrical shock, encompassing fire prevention, equipment protection, and personnel safety during operations and maintenance.

Proper Cabling Practices:

- Use cables rated for intended current and voltage.
- Ensure proper conductor sizing for anticipated load.
- Maintain appropriate cable routing to prevent mechanical damage.
- **Avoid daisy-chaining** power connections (can cause excessive voltage drop and heat).

Fuse Protection and Overcurrent Protection:

- PDUs should incorporate appropriate overcurrent protection devices (circuit breakers or fuses) rated for the connected load.
- Coordination between PDU protection and facility overcurrent protection prevents nuisance tripping.

Surge Protection:

- PDUs should incorporate appropriate overcurrent protection devices (circuit breakers or fuses) rated for the connected load.
- Coordination between PDU protection and facility overcurrent protection prevents nuisance tripping.

Additional Safety Considerations:

- Proper grounding of all equipment and PDUs.
- Regular inspection of connections and cables for signs of overheating or damage.
- Implementation of lockout/tag out procedures for maintenance activities.
- Training personnel on safe electrical work practices.





Maximizing Power Efficiency in Data Centers

Power efficiency improvements directly impact operational costs while reducing environmental footprint and heat generation. Efficiency gains compound throughout the power distribution chain, making PDU selection an important component of overall efficiency strategy.

- **Energy Star-rated PDUs:** Meet specific efficiency criteria and often incorporate advanced features that reduce power consumption. Look for PDUs with efficiency ratings of 95% or higher at typical load levels.
- **Power Usage Effectiveness (PUE) Measurement:** Provides insight into data center efficiency. Efficient PDUs contribute to improve PUE by reducing power distribution losses and enabling better load management.
- **Best Practices for Efficiency:**
 - Right-sizing PDUs to operate in their most efficient load ranges (typically 40-80% of rated capacity).
 - Implementing power monitoring to identify and eliminate inefficiencies.
 - Utilizing high-efficiency PDUs with advanced power factor correction.
 - Coordinating PDU selection with UPS systems to optimize overall power train
- **Load Balancing:** Across PDU circuits and phases helps maintain efficient operation while preventing hot spots. Regular power audits identify opportunities for improvement.



Conclusion

Powering Your Future Growth

Selecting the right PDU demands careful consideration of current requirements, future growth plans, and operational objectives. This decision profoundly impacts data center efficiency, reliability, and operational capabilities, while influencing long-term costs and scalability.

Key factors in PDU selection include:

- Matching input power characteristics to facility electrical infrastructure.
- Selecting appropriate output configurations for connected equipment.
- Choosing monitoring and control capabilities that align with operational requirements.
- Implementing proper safety and protection features.

The investment in quality PDUs pays dividends through improved operational efficiency, enhanced equipment protection, better capacity utilization, and reduced maintenance requirements. Whether deploying basic units in small installations or advanced switched PDUs in large facilities, proper selection and implementation create lasting value that supports business objectives and provides the foundation for future growth and evolution.

Data center power distribution is a critical infrastructure component that merits careful planning, quality component selection, and professional implementation. The guidance provided in this document enables informed decision-making, resulting in reliable, efficient, and scalable power distribution solutions tailored to specific operational requirements. ■

For Further Information And Inquiries, Please Contact:



Technology Movers



(855)703-6683



Sales @ Technology Movers . net



www. Technology Movers . net